

Candidacy Exam
 Department of Physics
 August 25, 2007

Part I

Instructions:

- The following problems are intended to probe your understanding of basic physical principles. When answering each question, indicate the principles being applied and any approximations required to arrive at your solution. *If information you need is not given, you may define a variable or make a reasonable physical estimate, as appropriate.* Your solutions will be evaluated based on clarity of physical reasoning, clarity of presentation, and accuracy.
- Please use a new blue book for each question. Remember to write your name and the problem number of the cover of each book.
- We suggest you read all *four* of the problems before beginning to work them. You should reserve time to attempt every problem.

Fundamental constants:

Avogadro's number	N_A	$6.022 \times 10^{23} \text{ mol}^{-1}$
Boltzmann's constant	k_B	$1.381 \times 10^{-23} \text{ J K}^{-1}$
Electron charge magnitude	e	$1.602 \times 10^{-19} \text{ C}$
Gas constant	R	$8.314 \text{ J mol}^{-1} \text{ K}^{-1}$
Planck's constant	h	$6.626 \times 10^{-34} \text{ J s}$
	$\hbar = h/2\pi$	$1.055 \times 10^{-34} \text{ J s}$
Speed of light in vacuum	c	$2.998 \times 10^8 \text{ m s}^{-1}$
Permittivity constant	ϵ_0	$8.854 \times 10^{-12} \text{ F m}^{-1}$
Permeability constant	μ_0	$1.257 \times 10^{-6} \text{ N A}^{-2}$
Gravitational constant	G	$6.674 \times 10^{-11} \text{ m}^3 \text{ kg}^{-1} \text{ s}^{-2}$
Standard atmospheric pressure	1 atmosphere	$1.01 \times 10^5 \text{ N m}^{-2}$
Stefan-Boltzmann constant	σ	$5.67 \times 10^{-8} \text{ W m}^{-2} \text{ K}^{-4}$
Electron rest mass	m_e	$9.109 \times 10^{-31} \text{ kg} = 0.5110 \text{ MeV } c^{-2}$
Proton rest mass	m_p	$1.673 \times 10^{-27} \text{ kg} = 938.3 \text{ MeV } c^{-2}$
Origin of temperature scales	$0^\circ\text{C} = 273 \text{ K}$	

Definite integrals:

$$\int_{-\infty}^{\infty} e^{-x^2} dx = \sqrt{\pi}.$$
$$\int_0^{\infty} x^n e^{-x} dx = \Gamma(n+1) = n!.$$

Indefinite integrals:

$$\int \frac{1}{\sqrt{x^2 + a^2}} dx = \ln\left(x + \sqrt{x^2 + a^2}\right).$$
$$\int \frac{1}{x^2 + a^2} dx = \frac{1}{a} \arctan \frac{x}{a}.$$
$$\int \frac{1}{(x^2 + a^2)^{3/2}} dx = \frac{x}{a^2 \sqrt{x^2 + a^2}}.$$

I-1. Three small balls of mass M are connected to form an equilateral triangle of side length L .

- (a) The connection is made by 3 rigid light rods. Derive a formula for the moment of inertia I around an axis at the center of the triangle, for rotation about an axis perpendicular to the plane of the triangle.
- (b) The connection is made by 3 light springs. The springs have a constant K and an unextended length L . The balls are rotated with constant angular frequency ω around the same axis as in part (a). What is the moment of inertia as a function of ω ?

(In this part assume that oscillatory motion has been damped out, so that the balls are at constant distances from each other.)

I-2. A particle of mass m is confined to a motion along a straight line such that it has a (quantum-mechanical) probability amplitude

$$\psi(x) = Ce^{-\alpha^2 x^2/2}. \quad (\text{I-1})$$

Calculate C in terms of α , and obtain an expression for the potential energy at coordinate x , if the total energy is

$$U = \frac{h^2\alpha^2}{8\pi^2m}. \quad (\text{I-2})$$

What is the probability of finding the particle in a small distance Δx centered at the point x ?

- I-3. Consider a straight wire carrying a charge Q uniformly distributed along its length L . Find the force acting on a charge q placed at point P which is at distance h from the line, along the perpendicular from its midpoint.

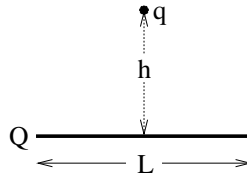

- I-4. A 500 g copper calorimeter can containing 300 g of water is in equilibrium at a temperature of 15°C . An experimenter now places 40 g of ice at 0°C in the calorimeter and encloses the latter with a heat-insulating shield.
- When all the ice has melted and equilibrium has been reached, what will be the temperature of the water? (The specific heat of copper is $0.39 \text{ J g}^{-1}\text{deg}^{-1}$, and the specific heat of water is $4.20 \text{ J g}^{-1}\text{deg}^{-1}$. Ice has a density of 0.917 g cm^{-3} and its heat of fusion is 333 J g^{-1} ; i.e., it requires 333 J to convert 1 g of ice to water at 0°C .)
 - Compute the total entropy change resulting from the process of part (a).
 - After all the ice has melted and equilibrium has been reached, how much work, in joules, must be supplied to the system (e.g., by mechanical agitation) to restore all the water to 15°C ?

Candidacy Exam
Department of Physics
August 25, 2007

Part II

Instructions:

- The following problems are intended to probe your understanding of basic physical principles. When answering each question, indicate the principles being applied and any approximations required to arrive at your solution. *If information you need is not given, you may define a variable or make a reasonable physical estimate, as appropriate.* Your solutions will be evaluated based on clarity of physical reasoning, clarity of presentation, and accuracy.
- Please use a new blue book for each question. Remember to write your name and the problem number of the cover of each book.
- We suggest you read all *four* of the problems before beginning to work them. You should reserve time to attempt every problem.

Fundamental constants:

Avogadro's number	N_A	$6.022 \times 10^{23} \text{ mol}^{-1}$
Boltzmann's constant	k_B	$1.381 \times 10^{-23} \text{ J K}^{-1}$
Electron charge magnitude	e	$1.602 \times 10^{-19} \text{ C}$
Gas constant	R	$8.314 \text{ J mol}^{-1} \text{ K}^{-1}$
Planck's constant	h	$6.626 \times 10^{-34} \text{ J s}$
	$\hbar = h/2\pi$	$1.055 \times 10^{-34} \text{ J s}$
Speed of light in vacuum	c	$2.998 \times 10^8 \text{ m s}^{-1}$
Permittivity constant	ϵ_0	$8.854 \times 10^{-12} \text{ F m}^{-1}$
Permeability constant	μ_0	$1.257 \times 10^{-6} \text{ N A}^{-2}$
Gravitational constant	G	$6.674 \times 10^{-11} \text{ m}^3 \text{ kg}^{-1} \text{ s}^{-2}$
Standard atmospheric pressure	1 atmosphere	$1.01 \times 10^5 \text{ N m}^{-2}$
Stefan-Boltzmann constant	σ	$5.67 \times 10^{-8} \text{ W m}^{-2} \text{ K}^{-4}$
Electron rest mass	m_e	$9.109 \times 10^{-31} \text{ kg} = 0.5110 \text{ MeV } c^{-2}$
Proton rest mass	m_p	$1.673 \times 10^{-27} \text{ kg} = 938.3 \text{ MeV } c^{-2}$
Origin of temperature scales	$0^\circ\text{C} = 273 \text{ K}$	

Definite integrals:

$$\int_{-\infty}^{\infty} e^{-x^2} dx = \sqrt{\pi}.$$
$$\int_0^{\infty} x^n e^{-x} dx = \Gamma(n+1) = n!.$$

Indefinite integrals:

$$\int \frac{1}{\sqrt{x^2 + a^2}} dx = \ln\left(x + \sqrt{x^2 + a^2}\right).$$
$$\int \frac{1}{x^2 + a^2} dx = \frac{1}{a} \arctan \frac{x}{a}.$$
$$\int \frac{1}{(x^2 + a^2)^{3/2}} dx = \frac{x}{a^2 \sqrt{x^2 + a^2}}.$$

II-1. An electron of mass m and velocity \mathbf{v} collides with an atom of mass M which in its ground state and which is at rest. After the collision, there is still just the electron and the atom, but the atom is excited to a higher energy level with energy ΔE above the ground state. Assume that the velocities of the atom and electron after the collision are parallel or antiparallel to the initial electron velocity.

Determine the minimum initial speed of the electron.

II-2. Positronium is a hydrogen-like system consisting of a bound state of an electron and a positron (the positron has the same mass as the electron and its electric charge is opposite to that of the electron). The lowest energy states are a singlet (vanishing total spin) and triplet (unit total spin) sub-state which are almost degenerate. The singlet state is the most stable, lying about 8.2×10^{-4} eV below the triplet levels which are themselves degenerate. Field theoretic calculations show that this splitting of the singlet and triplet is due to a spin-spin interaction of the form

$$H = -\frac{A}{\hbar^2} \mathbf{s}_1 \cdot \mathbf{s}_2 \quad (\text{II-1})$$

- (a) Determine the value of the constant A from the data.
- (b) Using the fact that the positron has a charge and magnetic moment that is opposite to that of the electron, find the energy levels in a magnetic field B , given that the size of the magnetic moment of the two particles is μ .

II-3. Two parallel, rectangular superconducting plates of length l , width b , and separation a ($l \gg b \gg a$) are joined at each end to form a one-turn coil of negligible resistance:

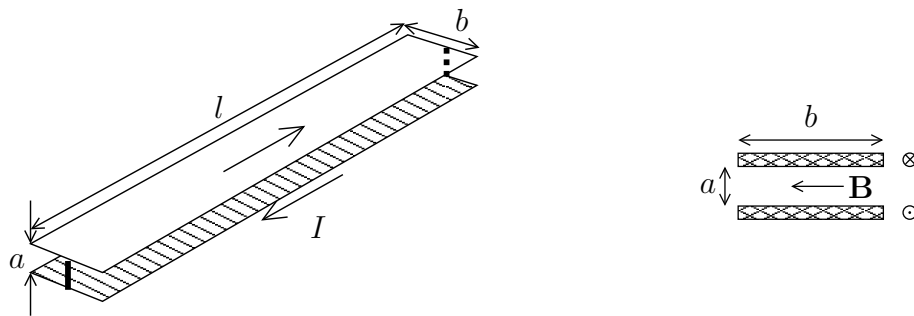

Assume that the magnetic field strength \mathbf{B} is constant between the plates when a steady current I flows, and that the magnetic field is zero outside. What is the self-inductance of this “coil”, and how much energy is stored in the magnetic field?

Now suppose the plates are moved such that the separation a is increased by a small amount δa ; this changes the stored energy. Determine the magnitude and direction of the force per unit area for each of the two plates.

II-4. A closed cylinder of radius a contains a gas at constant temperature T made of atoms each of mass m . The cylinder rotates about its axis with angular velocity ω . The total mass of gas contained in the cylinder is constant:

$$M = \pi a^2 L \rho_0, \quad (\text{II-2})$$

where ρ_0 is the initial density of the gas when the cylinder is not rotating.

When the cylinder rotates, the gas particles move towards the cylinder wall and the density increases with increasing radius r . However, thermal excitation opposes this motion.

Use the Boltzmann distribution law to derive an expression for this variation of the gas density with distance from the rotation axis.

